

ZL Bracket for 180kg 280kg electric [magnetic door lock](#)

Product Introduction

ZL shape bracket for electromagnetic lock

Model : DH-280ZL/DH-180ZL

Suitable for: wooden door, fireproof door

DH-280ZL use for single door electromagnetic lock (600LBS)

DH-180ZL use for single door electromagnetic lock (300LBS)







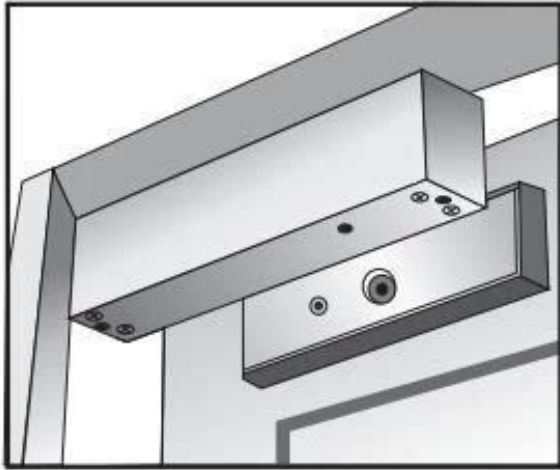

Armature Plate

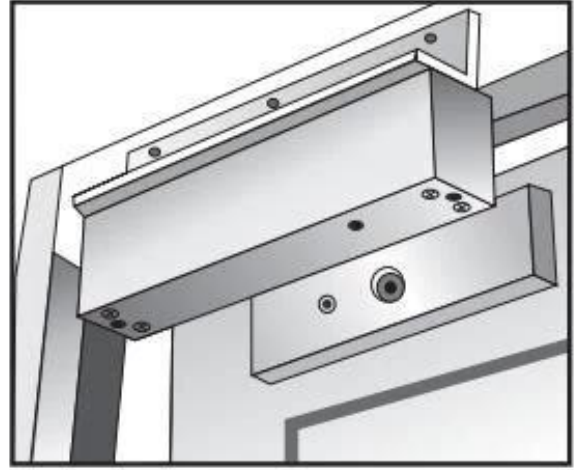

L BRACKET

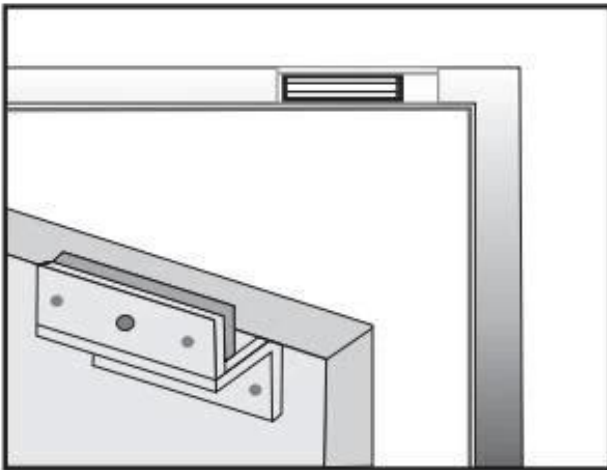

ZL BRACKET

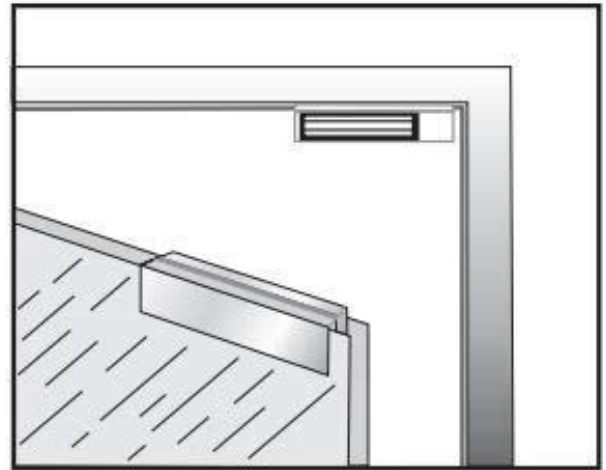

U BRACKET

► Optional Accessories

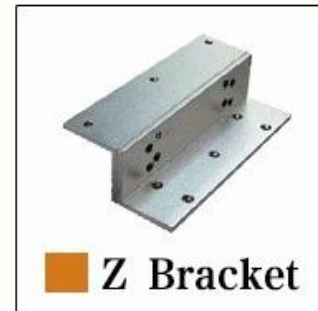
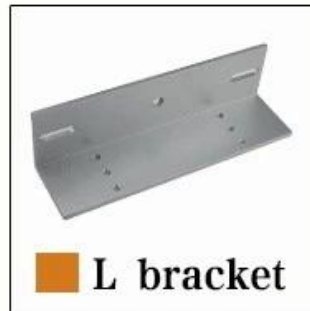

UDOHOW Magnetic lock Series

Holding Force : 180kg/375lbs		
DH-180G	DH-180A	DH-180GS
		
Holding Force : 280kgs/600lbs		
DH-280G	DH-280A	DH-280GS
		
Holding Force : 350kgs/750lbs		
DH-350G	DH-350A	DH-350GS
		
Holding Force:60KG/100lbs		Holding Force : 500kg/1200lbs
DH-60G		DH-500G
		

Our company

ABOUT US COMPANY INTRODUCTION

UDOHOW Electronics Co., Limited is a high-tech enterprise located in Guangdong Province, China. We're one of the leading manufacturers specialized in Intelligent Locks and Access Control Products including: Hotel Locks, Fingerprint Locks, Keypad Locks, Cabinets Locks, Electric Locks, Exit Switches and other related security access control products.

Our products have received good comments and trust of customers by superior quality, advanced innovation and considerate service.

[+ View More](#)



FACTORY / WORKSHOP / EXHIBITION



Our certificates

OUR CERTIFICATE



Contact us

CONTACT US



Sincerely for your service

You are welcome to come to consult

Contact: Winnie Liang

Cellphone/Wechat/Whatsapp: +86 13602510930

Skype: udohow1

Email: info@udohow.com

Web: www.udohow.com

Click Back Home